

Cleanfire® ThruPort_e™ Burner

A solution for aging regenerators in the glass industry

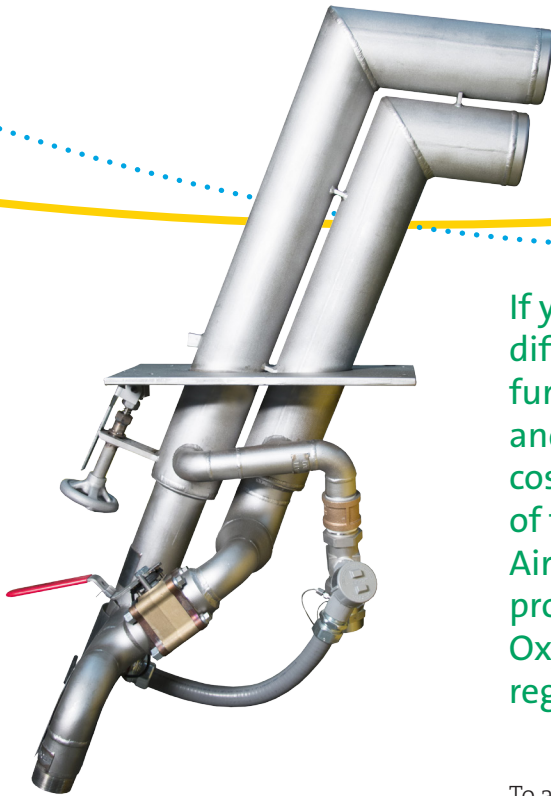

If you're undergoing regenerator repairs or having difficulty maintaining full production in an aging glass furnace, you may be experiencing reduced pull rate and shortening of your furnace campaign—both are costly consequences that could amount to the loss of tens of thousands of dollars in revenue per day. Air Products has a solution for you. With our patent-protected* and commercially-proven Cleanfire ThruPort_e Oxy-fuel burner, you can breathe life into those ailing regenerators.

To avoid downtime during regenerator repairs or extend the life of an aging furnace, our ThruPort_e burner can be easily installed through your existing furnace port to efficiently add heat and help maintain your desired production level—while delivering high efficiency and low NO_x emissions. To do this, the burner takes advantage of several unique features:

- Tandem, water-cooled oxy-fuel burner and oxygen staging lance assembly
- Natural gas and oil-fired versions, with firing capacity in the range of 4–20 MMBtu/hr
- Proven, durable design that can be easily installed in an existing port, while the furnace is running
- Adjustable flame length and angle for optimal heat distribution and surface coverage
- Optional state-of-the-art on-burner diagnostic sensors and wireless communications technology—providing instantaneous remote access to up to-date burner operating parameters
- Available for rapid deployment

The ThruPort_e burner allows you to adjust the flame length and angle with ease for optimal heat distribution and surface coverage.



0 degree tilt, 0 staging



0 degree tilt, full staging



5 degree tilt, full staging

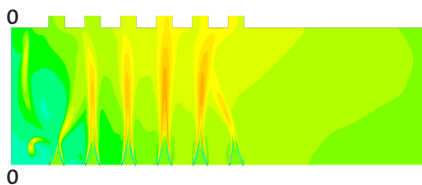

CFD-predicted combustion space temperature profile for baseline air-fuel operation with zero-port boost burners

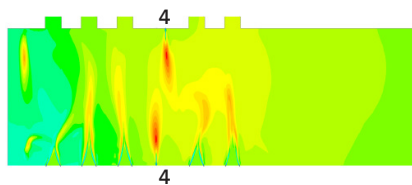

CFD-predicted combustion space temperature profile with ThruPort_e burners in ports 4

Computational Fluid Dynamics (CFD) Modeling demonstrates that adding the two burners generates high temperature flames directly above the hot spot of the glass melting tank, which is ideal for reinforcing critical glass recirculation flow patterns and increasing glass residence time in the melter.

		Baseline	Fouled Regenerators	ThruPort _e TM
Pull Rate	TPD	650	600	650
Fuel Firing Rate	MMBtu/hr	163.0	149.9	147.1
Air Flow Rate	scfh	1,681,100	1,512,990	985,000
Air Preheat Temperature	deg C	1250	1250	1250
Oxygen to Boost Burners	scfh	30,000	30,000	30,000
Oxygen Flow Rate to ThruPort _e Burners	scfh	0	0	60,000
Oxygen to Lances	scfh	0	0	40,000
Glass Temperature at Throat	deg C	1296	1270	1286
Flue Gas Temperature	deg C	1501	1476	1321
Specific Energy Consumption	MMBtu/ton	6.02	6.00	5.43

Key inputs and results from CFD modeling of the Cleanfire ThruPort_e burner technology in a 650 tpd float glass furnace, demonstrating the detrimental effect of fouled regenerators on pull rate and the benefit of adding ThruPort_e burners.

* Cleanfire is a registered trademark of Air Products and Chemicals, Inc. and ThruPort/ThruPort_e are grade designations under that trademark covered by one or more patents and pending applications, including US 9,221,704.

For more information

Air Products experts would be happy to help you understand if the Cleanfire ThruPort_e burner is a good fit for your needs. Please contact us to learn more or request a demonstration in our pilot-scale Advanced Clean Energy lab. To make glass better, put Air Products in the mix!

Corporate Headquarters

Air Products and Chemicals, Inc.
7201 Hamilton Boulevard
Allentown, PA 18195-1501
T 800-654-4567 or 610-706-4730
F 800-272-4449 or 610-706-6890
gigmrktg@airproducts.com

Asia

Air Products and Chemicals (China)
Investment Co Ltd
2nf Floor, Building 88
887 Zu Chong Zhi Road
Zhangjiang Hi-tech Park
Shanghai, P.R.C. 201203
Hotline: 400 888 7662 (China only)
T (86) 21 3896 2000
F (86) 21 5080 7525
asiacmb@airproducts.com

Europe

Air Products PLC
Hersham Place Technology Park
Molesey Road
Walton-on-Thames
Surrey KT12 4RZ
UK
T +44 (0) 800 389 0202
T +44 (0) 1270 612708
apukinfo@airproducts.com



tell me more
airproducts.com/thruport